

Object: Data Sheet item 80075AB



Antibacterial plug french/german standard 2P+E 16A demountable white

- Colour: white
- Voltage: 250V~
- Frequency: 50/60Hz
- Rated current: 16A
- Standard: German/French
- Cable outlet position: to the side 90° or axial
- Made in Italy
- Packaging: single flow pack
- Net weight: 30,1g
- Brass, nickel-plated contacts and earth contact

MANUFACTURED WITH SILVER IONS ADDITIVES
WHICH GUARANTEE AN ANTIBACTERIAL ACTIVITY

FANTON S.p.A.

Società soggetta a direzione e coordinamento da parte di Fa.Mi. srl

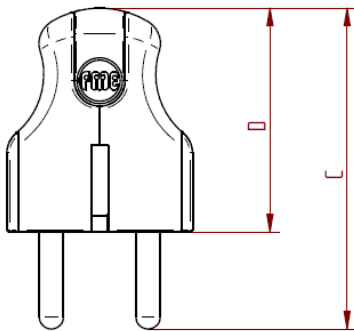

Codice	A	B	C	D
80075	36	36	62	44
80076	36	36	62	44

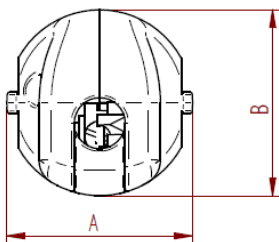

Fanton spa reserves the right to change and update the product at any time and without warning.
Date: 06/08/2020 Revision: 0

FANTON S.p.A.

Società soggetta a direzione e coordinamento da parte di Fa.Mi. srl

Viale dell'Industria, 8/10
35026 CONSELVE (PD) ITALY
Web: <http://www.fanton.com>
info@fanton.com

P.I./VAT - IT 02353470285
Tel. +39.049.95.97.911
Fax+39.049.95.00.311
amministrazione@pec.fanton.com