

Object: Data sheet item 81085AB



Antibacterial adaptor from plug S31 16A to socket UK with mobile phone holder, white

- Colour: white
- Voltage: 250V~
- Plug 16A french/schuko standard
- Socket : british-schuko-italian standard
- Frequency: 50/60Hz
- Max power supply: 1500W
- Made in Italy
- With mobile phone holder
- Packaging: single flow pack
- Net weight: 46g
- Brass shielded pockets

**MANUFACTURED WITH SILVER IONS ADDITIVES
WHICH GUARANTEE AN ANTIBACTERIAL ACTIVITY**

FANTON S.p.A.

Società soggetta a direzione e coordinamento da parte di Fa.Mi. srl

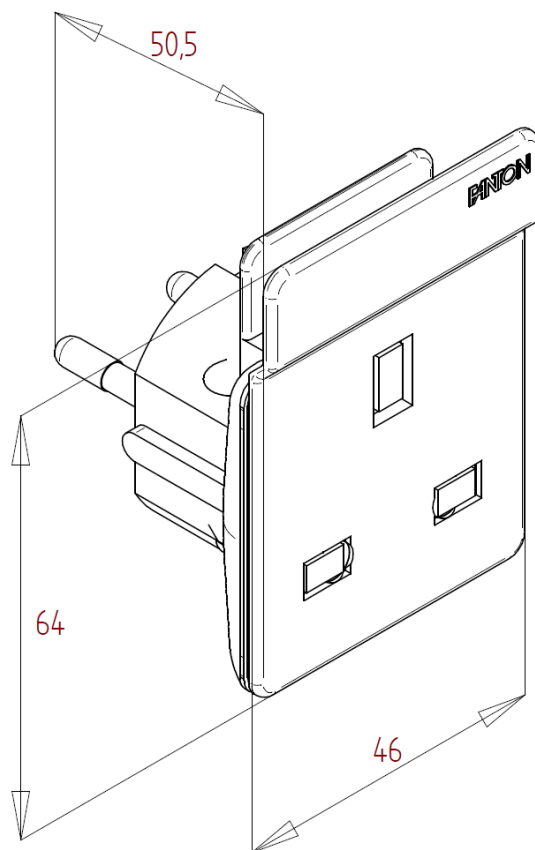

Fanton spa reserves the right to change and update the product at any time and without warning

Date: 06/08/2020

Revision: 0

FANTON S.p.A.

Società soggetta a direzione e coordinamento da parte di Fa.Mi. srl

Viale dell'Industria, 8/10
35026 CONSELVE (PD) ITALY
Web: <http://www.fanton.com>
info@fanton.com

P.I./VAT - IT 02353470285
Tel. +39.049.95.97.911
Fax+39.049.95.00.311
amministrazione@pec.fanton.com